

REV	DESCRIPTION	BY DATE	APPD
A	RELEASED PER ECR 7469	KJT 09/11/02	[Signature]

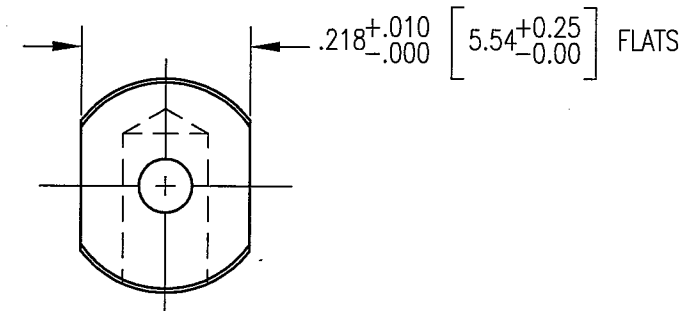
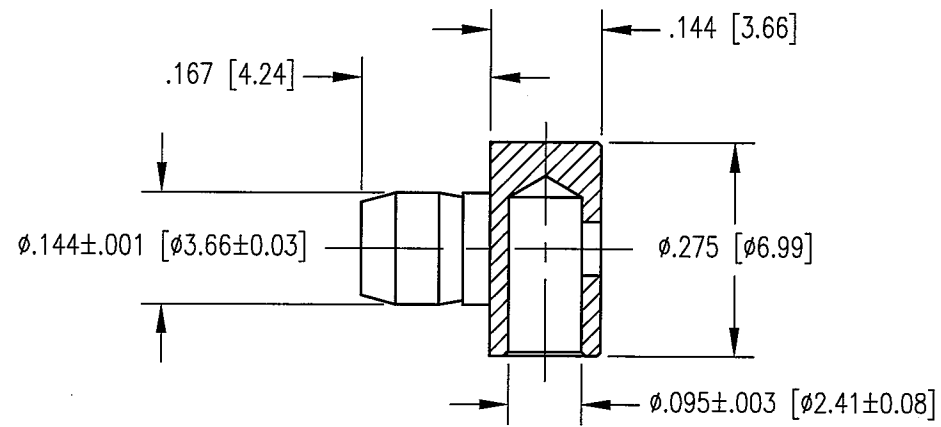

NOTES:

- MATERIALS:
BODY: BRASS PER ASTM B16
- FINISH:
BODY: .000030 MIN. GOLD PER MIL-G-45204 OVER
.000050 MIN. NICKEL PER QQ-N-290
- FOR USE WITH 2.5mm² OR EQUIVALENT WIRE.

PER ASME Y14.5M-1994 UNLESS OTHERWISE SPECIFIED: DIMENSIONS ARE IN INCHES [MM]		NORTHROP GRUMMAN	
TOLERANCES: DECIMALS .XX ± .01 [0.254] .XXX ± .005 [0.127] ANGLES ± 2°		Winchester Electronics 400 Park Road Watertown, CT 06795	
CUSTOMER DRAWING		TITLE RIGHT ANGLE 20 AMP PLUG	
DRAWN KJT	DATE 01/31/02	CHECKED JWH	DATE 2/1/02
APPROVED JEM	DATE 2/1/02	APPROVED JED	DATE 2/1/02
A		01332	SHT. OF REV. 1 1 A